

This Page Is Inserted by IFW Operations
and is not a part of the Official Record

BEST AVAILABLE IMAGES

Defective images within this document are accurate representations of the original documents submitted by the applicant.

Defects in the images may include (but are not limited to):

- BLACK BORDERS
- TEXT CUT OFF AT TOP, BOTTOM OR SIDES
- FADED TEXT
- ILLEGIBLE TEXT
- SKEWED/SLANTED IMAGES
- COLORED PHOTOS
- BLACK OR VERY BLACK AND WHITE DARK PHOTOS
- GRAY SCALE DOCUMENTS

IMAGES ARE BEST AVAILABLE COPY.

**As rescanning documents *will not* correct images,
please do not report the images to the
Image Problem Mailbox.**

(19) Japanese Patent Office (JP)
(12) Publication of Unexamined Patent Application (A)

(11) Unexamined Patent Application No.: S55-29002
(43) Unexamined Patent Application Date: March 1, 1980
Request for Examination: Yes
Number of Claims: 1
Total pages: 6

| (51) Int. CL ^N | Identification Symbol | JPO File Number | FI | Technology Display Area |
|---------------------------|-----------------------|-----------------|----|-------------------------|
| F 02 D | 17/00 | 7910-3G | | |
| | 5/02 | 6355-3G | | |

(54) Title of Invention: Fuel Supply Control Variable Cylinder System

(21) Patent Application No.: S55-29002

(22) Patent Application Date: July 17, 1978

(72) Inventor: Shin Sugawara
3-5-20 Nakahara, Isogo-ku, Yokohama City, Kanagawa Prefecture

(72) Inventor: Haruhiko Iizuka
2-50-4 Hairando, Yokosuka City, Kanagawa Prefecture

(72) Inventor: Junichiro Matsumoto
3-68 Oppama Higashi-cho, Yokosuka City, Kanagawa Prefecture

(71) Applicant: Nissan Motor Corp. Ltd.
2 Takara-cho, Kanagawa-ku, Yokohama City

(74) Agent: Patent Attorney, Masayoshi Goto

Specification

Title of Invention

Fuel Supply Control Variable Cylinder System

Claim(s)

1. A fuel supply control type variable cylinder system for multi-cylinder engines equipped with a fuel supply system and a variable cylinder control circuit that permit partial cylinder operation by shutting off the supply of fuel to a specified group of cylinders from the fuel supply system depending on engine load, comprising a three-way catalyst and a first oxygen sensor located in the exhaust passage of the active cylinder group; a three-way catalyst and a second oxygen sensor located in the merged passage where the exhaust passage of the inactive cylinder group meets the downstream of the exhaust passage mentioned above; a selection circuit that selects the output of the first oxygen sensor under partial cylinder operation or the output of the second oxygen sensor under full cylinder operation depending on shut-off of the variable cylinder system circuit mentioned above; a temperature detection means that detects the temperature of the three-way catalyst in the merged passage; and an air-fuel ratio control circuit in which the fuel supply signal mentioned above terminates the shut-off operation when the temperature detection means detects that the temperature is below a specified value, while interrupting the air-fuel ratio control that controls the fuel supply signal in such a manner so as to make the air-fuel ratio become equal to the stoichiometric value.
2. The fuel supply control type variable cylinder system described in claim 1, a unique feature of which is that the temperature detection means mentioned above represents a circuit that determines the temperature by detecting that one portion of said fuel supply signal is shut off and that the output of the second oxygen sensor is higher than a specified value.

Detailed Explanation of the Invention

This invention concerns a fuel supply control type variable cylinder system engine equipped with a three-way catalyst in the exhaust system to feedback-control the air-fuel ratio; in particular, a system in which degradation of the exhaust emission control operation is prevented by resuming the full cylinder operation whenever the catalyst temperature decreases.

Generally speaking, engine fuel economy tends to improve when the engine is operated under a heavy load condition. This is the reason the variable cylinder engine concept was developed for multi-cylinder engines to stop the fuel supply to one group of the cylinders under a light engine load so that the relative load per each of the remaining cylinders can be increased leading to improved fuel economy under light load conditions.

On the other hand, from the standpoint of exhaust emission control measures, there is a well-known system in which a three-way catalyst is installed in the engine exhaust system, upstream of which an exhaust sensor (oxygen sensor) is installed. In this system, the air-fuel ratio is feedback-controlled to become approximately equal to the stoichiometric value based on the output of this exhaust sensor in order to achieve high efficiency oxidation of HC and CO concurrently with reduction of NOx.

When this air-fuel ratio control system is employed with a variable cylinder engine, when a cylinder

group is inactive, the air exhausted from these inactive cylinders is mixed with the combustion exhaust gas from the active cylinders before it passes through the oxygen sensor and the three-way catalyst. This results in oxygen sensor output that indicates an oxygen rich condition so the feedback control forces the system to make the air-fuel ratio extremely lean, which in turn tends to degrade fuel economy.

One measure to address this problem is to install oxygen sensors and three-way catalysts in the exhaust passage of the cylinders that are always active as well as in the merged exhaust passage in which the exhaust passages from the active cylinders and inactive cylinders are joined. When one portion of the cylinders is inactive, feedback control is performed based only on the output of the oxygen sensor through which the exhaust gas from the active cylinders passes making the air-fuel ratio of the combustion exhaust gas approximately equal to the stoichiometric value. In this manner, the system can achieve good fuel economy and emission control at the same time.

There is, however, a problem during the engine warm-up period or during the time when the partial cylinder operation lasts a long time. The exhaust gas temperature tends to become low under these conditions, especially the temperature of the downstream three-way catalyst. It undergoes a large-scale decrease from its normal activated condition resulting from the entry of exhausted air from the inactive cylinders.

When the engine resumes full cylinder operation after the decrease in catalyst temperature, it is difficult to achieve good reaction at the downstream three-way catalyst which results in partial degradation of its exhaust emission control performance. This phenomenon tends to occur when a vehicle starts climbing uphill after it has been driven on a gently sloping downhill under the partial cylinder mode for a long time.

In order to eliminate this type of problem, there have been measures such as installing temperature sensors in the three-way catalysts in the exhaust passages. Whenever these temperature sensors detect a decrease in catalyst temperature below a specified value, the variable cylinder control system mode is interrupted to restore the full cylinder mode and expedite a quick increase in catalyst temperature. This measure, however, requires special temperature sensors and, inevitably, leads to cost escalation.

There is another measure in which a low engine temperature condition is detected by the engine coolant temperature and interrupting the variable cylinder control system. However, this system is still unable to solve the problem when the full cylinder operation is resumed, and tends to lower engine response characteristics.

Moreover, in the air-fuel ratio feedback control system mentioned above, similar to the three-way catalyst, the output characteristics of the oxygen sensors also tend to fluctuate and deviate from the proportionality with respect to the oxygen concentration when its temperature is decreased, resulting in impairment of the feedback control accuracy.

In order to address this problem, a normal procedure is to "clamp" the feedback signal to maintain the air-fuel ratio at a fixed value so that feedback control of the air-fuel ratio can be temporarily interrupted when the temperature estimated from the output of the oxygen sensor is determined to be below a specified value.

Based on such background, this invention is designed to assure the exhaust emission control performance

of a variable cylinder engine to control the air-fuel ratio based on the output of the oxygen sensor, which is located near the exhaust inlet of the three-way catalyst for the partially active cylinders, and which has similar temperature characteristics as those of the three-way catalyst temperature. When the downstream oxygen sensor temperature decreases below a specified value, feedback control of the air-fuel ratio is interrupted while at the same time the variable cylinder control system operation is also interrupted to restore full cylinder operation. With this method, the three-way catalyst temperature can be quickly increased by the combustion exhaust from all cylinders to prevent a decrease in the three-way catalyst temperature so that the good exhaust emission control operation can be maintained. The purpose of this invention is to introduce a fuel supply type variable cylinder engine that will achieve the performance explained above.

Next, a working example of this invention is presented using illustrations.

Number 1 represents the engine body, while f1 ~ f3 are inactive cylinders, the operation of which is stopped during the light load condition as explained later, and f4 ~ f6 are cylinders that are always active. Numbers 2a ~ 2f represent fuel injection valves installed in the intake ports of these cylinders, while 3 is an intake pipe, 4 a throttle valve, 5 an intake air flow sensor, and 6a and 6b are exhaust pipes for cylinder groups f1 ~ f3 and f4 ~ f6, respectively. 7 is a three-way catalyst installed in exhaust pipe 6b, and 8 is an oxygen sensor installed near the inlet of this three-way catalyst. 9 is a three-way catalyst installed in a merged pipe, 6, between exhaust pipes 6a and 6b, while 10 is an oxygen sensor installed near the inlet of three-way catalyst 9.

As described later, the air-fuel ratio control circuit, 12, receives the output of oxygen sensors 8 and 10 as input through a selection relay, 11, that performs the switching action based on the signal from a variable cylinder control circuit, 16, which is explained later. As depicted in Fig. 2, air-fuel ratio control circuit 12 is comprised of a comparator, 13, which compares the sensor output with the comparison standard voltage; a standard voltage setting device, 14, that outputs standard voltage corresponding to the stoichiometric air-fuel ratio; a correction waveform generation circuit, 16, that receives base pulses from a terminal, 15; a low catalyst temperature detector, 17, that detects the low temperature condition of oxygen sensor 10; and a clamp circuit, 20, which clamps (sets the air fuel ratio feedback valve at a specified valve irrespective of the outputs of oxygen sensors 8 or 10) the feedback control value by receiving the low temperature signal from detector 17, and by receiving the full-throttle signal at the time of a fully open output and the fuel-cut signal at the time of deceleration from terminals 18 and 19.

A fuel injection control circuit (EGI circuit), 15, determines the amount of fuel injection based on the air-fuel ratio control signal from air-fuel ratio control circuit 12, and the signals from intake airflow sensor 5 and rpm sensor 21. Although the output of the EGI circuit is applied directly to fuel injection valves 2d ~ 2f, it is applied to other fuel injection valves 2a ~ 2c through a variable cylinder control circuit (VCS circuit, hereafter), 16. When a light load condition is detected by this VCS circuit 16, the fuel supply to fuel injection valves 2a ~ 2c is shut off making cylinders f1 ~ f3 inactive. At the same time, the system is designed such that selection relay 11 is switched to the side of oxygen sensor 8, which is exclusively provided for active cylinders f4 ~ f6 by the same signal generated by the VCS circuit 16 to decrease the

number of cylinders.

In principle, VCS circuit 16 is designed so as not to send the fuel injection pulse signal from EGI circuit 15 to fuel injection valves 2a ~ 2c during light load conditions making cylinders f1 ~ f3 inactive so that the fuel economy can be improved during light load conditions. The basic configuration is comprised of pulse comparators, 22 and 23, for the fuel injection signal having a pulse width proportional to engine load; pulse width setting devices, 24 and 25, that output the pulse setting values (W_H) and (W_L) corresponding to the heavy and light load conditions as comparison standard values; an engine rpm comparator, 26; an rpm setting device, 27, that makes the specified low rpm setting (N_0) be the standard value; a flip-flop, 30, that sends the outputs from an "OR" circuit, 28, and an "AND" circuit, 29, to "set input (S)" and "reset input (R)" respectively; an "OR" circuit, 31, that inputs the output of this flip-flop 30 and the low temperature detecting device 17 of the air-fuel ratio control circuit 12 mentioned above; and an "AND" circuit, 32, that receives the outputs of "OR" circuit 31 and EGI circuit as its inputs. In other words, since low temperature detecting device 17 is connected to the input side of "OR" circuit 31, the circuit is configured such that the partial cylinder deactivation command from VCS circuit 16 is cancelled when the temperature of oxygen sensors 8 and 10 is low.

Next, the operation of this invention is explained. Fig. 3 shows when engine rpm (N) and fuel injection pulse width (W) are in the 6-cylinder operation region. In this condition, as explained later, the output level of flip-flop 30 in the VCS circuit 16 becomes "1," and cylinders f1 ~ f3 are in the active condition, in other words, the system is in the full cylinder mode. After this, selection relay 11 is energized by receiving the output of "OR" circuit 31, which is "1" to perform the switching action, and the output of oxygen sensor 10, which detects the exhaust temperature of all cylinders, is input to air-fuel ratio control circuit 12. The output of comparator 13, which compares the oxygen concentration in the exhaust gas with the standard value corresponding to the stoichiometric air-fuel ratio generated by standard setting device 14, is fed back to EGI circuit 15 through clamp circuit 20 after it detects the deviation signal from the standard pulse at correction waveform generation circuit 16. Through these steps, the air-fuel ratio converges approximately to the stoichiometric value so that three-way catalyst 10 (*sic*) can function correctly. When the engine enters the light load condition, causing pulse width (W) and engine rpm (N) to shift to the 3-cylinder region indicated in Fig. 3, the output level of flip-flop 30 becomes "0" and the operating condition of cylinders f1 ~ f3 becomes inactive. At this time, since low temperature detector 17 outputs the signal "0" indicating that oxygen sensor 10 is not at a temperature below the specified value, the output of "OR" circuit 31 becomes "0," closing the gate of "AND" circuit 32. At the same time, selection relay 11 is de-energized by the output "0" of "OR" circuit 31, and is switched over to the oxygen sensor 8 side as indicated in Fig. 2 so that the system is controlled in such a way that three-way catalyst 7 in the active cylinder group side consisting of cylinders f4 ~ f6 can exhibit high conversion efficiency.

When this partial cylinder operation condition continues for a long time, or during the engine warming-up period, the exhaust gas temperature entering the catalyst decreases. If the temperature becomes so low that catalyst 9 and oxygen sensor 10 can no longer function properly, low temperature detector 17 outputs

the level "1" signal to force the feedback signal to assume the "clamp" condition through clamp circuit 20. When the "clamped" signal value is applied to EGI circuit 15, the air-fuel ratio is controlled to hold at a specified fixed value. In this case, however, the control accuracy becomes slightly lower than in the case of feedback control, resulting in the situation that the function of three-way catalyst 9 tends to become degraded. In order to end this condition as quickly as possible, it is best to resume full cylinder operation. To comply with this requirement, in this invention, the output of low temperature detector 17 is input to "OR" circuit 31 to make cylinders f1 ~ f3 active whenever the low temperature detection signal (level "1" signal) is output, regardless of the output level of flip-flop 30. As a result of this forced restoration of full cylinder operation, when the exhaust temperature increases gradually to restore the function of three-way catalysts 7 and 10 (*sic*), and as long as the engine is in the light load condition during this period, the system is switched back to the 3-cylinder operation mode, provided that the clamp signal is retracted.

Next, the operation of VCS circuit 16 is briefly described here. Since the output of EGI circuit 15 is directly applied to fuel injection valves 2d ~ 2f for cylinders f4 ~ f6, the cylinder group consisting f4 ~ f6 is always in the active state. Although other cylinders f1 ~ f3 are in the active state as long as "AND" circuit 32 gate is open, they assume the inactive state when the output level of flip-flop 30 becomes "0" and low temperature detector 17 is not generating the detection signal (output of "0"). In other words, when the detection signal is output, cylinders f1 ~ f3 retain the active state even when the output level of flip-flop is "0." Moreover, the output level of flip-flop 30 becomes "1" when pulse width (W) is greater than the standard (W_H) or when rpm (N) is lower than the standard value (N_0) (the 6-cylinder region in Fig. 3), and it becomes "0" when pulse width (W) becomes lower than the standard (W_L) and rpm (N) becomes higher than the standard (N_0) (the 3-cylinder region in Fig. 3). Since the "set" input terminal of flip-flop 30 is connected to "OR" circuit 28, and the "reset" input terminal of flip-flop 30 is connected to "AND" circuit 29, the region indicated by "maintain the same number of cylinders" in Fig. 3 is formed.

As explained above, according to this invention, it is possible to always maintain a high catalytic conversion efficiency of the three-way catalyst since the variable cylinder control is interrupted when the oxygen sensor is at the temperature condition under which it does not function properly, and full cylinder operation is maintained even under the light load condition to achieve a rapid temperature increase in the entering exhaust gas to restore the three-way catalyst function. Compared with the system in which variable cylinder control is performed by detecting engine coolant temperature, since in this invention variable cylinder control is performed by detecting the low temperature condition of the oxygen sensor that is sensitive to temperature change, it is possible to obtain accurate controls having good response characteristics. Another effect is that the system configuration is not complicated and is less expensive.

Brief Explanation of Figures

The figures show one working example of this invention. Figure 1 is a simplified configuration diagram of the overall system, Fig. 2 is a block diagram of the control system, and Fig. 3 explains the variable cylinder control pattern.

f1 ~ f6. . . Cylinders

- 2a ~ 2f . . . Fuel Injection Valves
- 8 and 10 . . . Oxygen Sensors
- 12 . . . Air-Fuel Ratio Control Circuit
- 15 . . . Fuel Injection Control Circuit
- 16 . . . Variable Cylinder Control Circuit
- 17 . . . Low Temperature Detector

Applicant: Nissan Motor Company, Ltd.

Agent: Patent Attorney, Masayoshi Goto

Amendment

Sept. 25, 1979

To:

Honorable N. Kawahara, Director General

Japanese Patent Office

1. Case Identifier

1978 Patent No. 86996

2. Title of Invention

Fuel Supply Control Variable Cylinder System

3. Party Filing Amendment

Relationship to Case: Patent Applicant

Address: Muromachi-2, Kanagawa-ku, Yokohama City, Kanagawa Prefecture

Name: Nissan Motor Company, Ltd. (399)

4. Agent

Address: Third Floor, Ginza 8-10 Bldg.

Ginza 8-10-8, Chuuo-ku, Tokyo, 104

Tel: 03-574-8464 (Main)

Name: (7551) Patent Attorney, Masayoshi Goto

5. Date of Amendment Order: Voluntary

6. Subject of Amendment

Item "Claim(s)"

7. Description of Amendment

1) "Claim(s)" on page 1 or 2 of Specification shall be amended as follows:

"Claim(s)

1. A fuel supply control type variable cylinder system for multi-cylinder engines equipped with a fuel supply system and a variable cylinder system control circuit that permit partial cylinder operation by shutting off the supply of fuel to a specified group of cylinders from the fuel supply system depending on engine load, comprising a three-way catalyst and a first oxygen sensor located in the exhaust passage of the active cylinder group; a three-way catalyst and a second oxygen sensor located in the merged passage

where the exhaust passage of inactive cylinder group meets the downstream of the exhaust passage mentioned above; a selection circuit that selects the output of the first oxygen sensor under partial cylinder operation or the output of the second oxygen sensor under full cylinder operation depending on the shut-off of the variable cylinder system circuit mentioned above; a temperature detection means that detects the temperature of the three-way catalyst in the merged passage; and an air-fuel ratio control circuit which interrupts the shutting off operation of the fuel supply signal mentioned above when the temperature detection means detects that the temperature is below a specified value, while interrupting the air-fuel ratio control that controls the fuel supply signal in a manner so as to make the air-fuel ratio become equal to the stoichiometric value.

2. The fuel supply control type variable cylinder system described in claim 1, a unique feature of which is that its temperature detection means mentioned above represents a circuit that determines the temperature by detecting that one portion of the fuel supply signal is shut off and that the output of the second oxygen sensor is higher than a specified value.”

FIGURES

Fig. 1

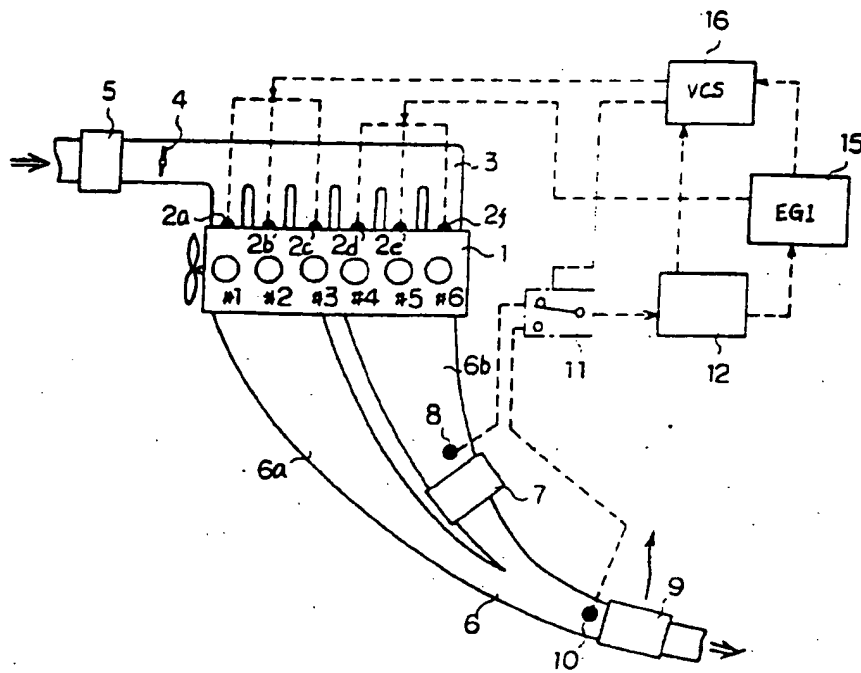

FIGURES

Fig. 2

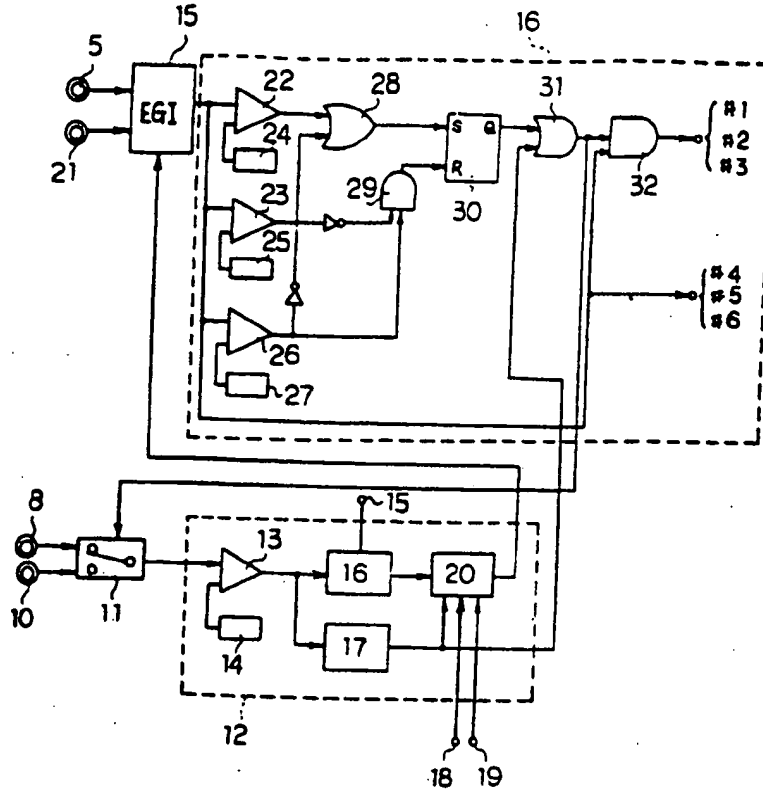

Fig. 3

